

PERMANENT MAGNET SHAKER

DYN-PM-101

DynaLabs permanent magnet shakers create motion by magnets and coils pushing and pulling each other, similar to the technology used in loudspeakers.



DynaLabs permanent magnet shakers create motion by magnets and coils pushing and pulling each other, similar to the technology used in loudspeakers. The PM-101 shaker is identical to the PM-100, except it does not include an integrated amplifier. For those requiring an amplifier, the SA-400 and SA-500 models are available. With its lightweight design and powerful performance, it is the ideal solution for modal and vibration testing.



Advantages

- Lightweight, durable, portable and easy to use
- Adjustable trunnion base provides high degree of flexibility
- Broad frequency range
- External amplifier (SA-400 or SA-500)



Application Areas

- Vibration testing of small parts
- Sensor calibration
- Modal testing
- Shock testing
- Fatigue and resonance testing



DYNALABS MUHENDISLIK LTD STI

Ostim OSB Mah. 100 Yil Bulvarı Ostim
No:55B/11 Yenimahalle 06374 Ankara
TURKEY

Phone: +90 312 386 21 89

Mail: dynalabs@dynalabs.com.tr

Web: www.dynalabs.com.tr

DynaLabs PERMANENT MAGNET SHAKER

DYN-PM-101

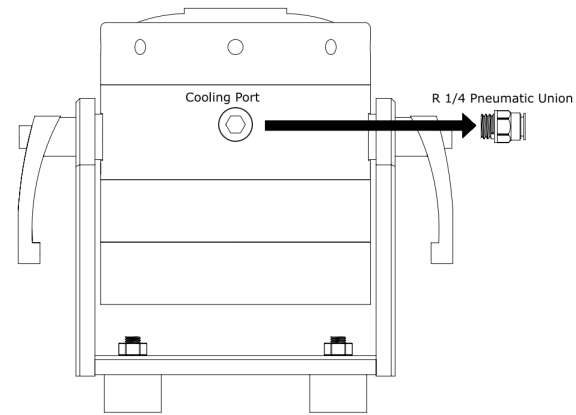
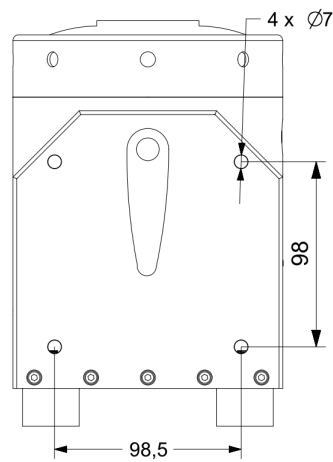
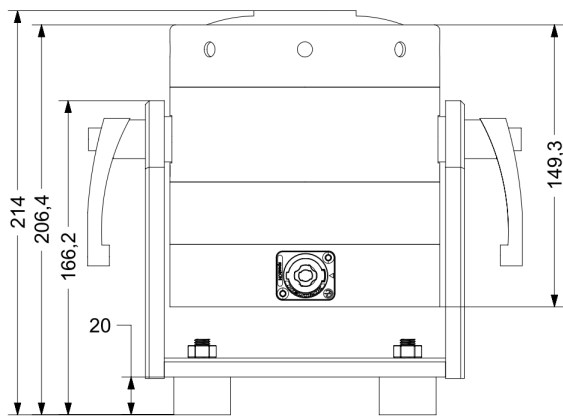
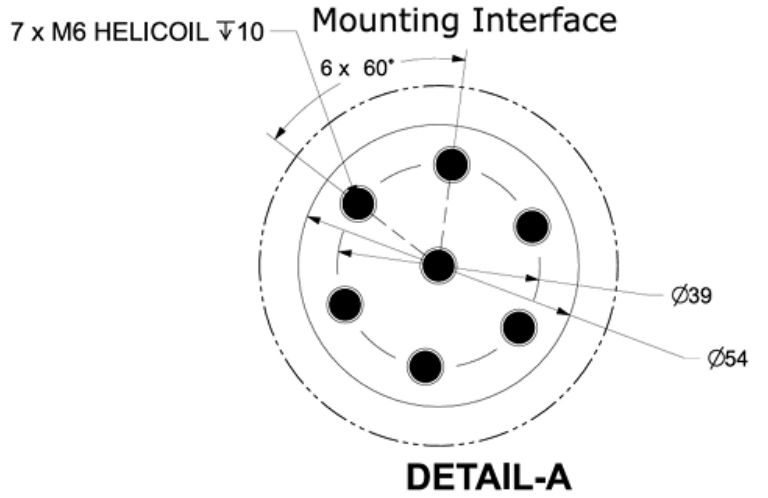
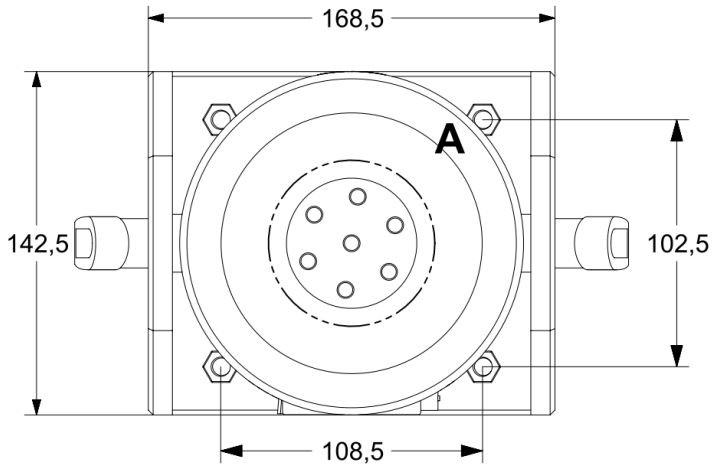

Output Force (Sinus)	Frequency Range	Max Payload (Vertical)	Displacement (P-P)	Maximum Acceleration	Shaker Weight	
100 N	0-7.5 kHz	1.5 kg	10 mm	60 g	7.3 kg	
Cooling System	Armature Weight	Operating Temp. Range	Suspension	Maximum Input Current	AMPLIFIER	Max Velocity
Natural Convection	170 gr	5-35 °C	Carbon Fiber	6A (RMS)	Optional (SA-400 / SA-500)	1 m/s



DYNALABS MUHENDISLIK LTD STI

Ostim OSB Mah. 100 Yil Bulvarı Ostim
No:55B/11 Yenimahalle 06374 Ankara
TURKEY

Phone: +90 312 386 21 89

Mail: dynalabs@dynalabs.com.tr

Web: www.dynalabs.com.tr